

LECTURE 2: INTRODUCTION TO THE PENTATEUCH

Jason S. DeRouchie, PhD

Contents		
I.	The Pentateuch's Makeup, Unity, Structure, & Message	1
A.	Titles	1
B.	Narrative & Canonical Flow	2
C.	Major Characters in the Plot	2
D.	Component Parts	2
E.	The Development of "God's Kingdom" in the Pentateuch	3
II.	Pentateuchal Authorship, Composition, and Historicity	4
A.	The Traditional View	4
B.	Some Challenges to the Traditional View	6
C.	An Initial Response to the Challenges Related to Pentateuch's Authorship and Composition	13
D.	An Initial Response to the Challenges Related to Questions of Historicity	21
E.	Summary Support for the Traditional View of Substantial Mosaic Authorship of the Pentateuch	24

I. The Pentateuch's Makeup, Unity, Structure, & Message

A. Titles:

1. "Pentateuch" from the Greek *penta* (five) and *teuchos* (tool, vessel, book)
2. "Torah": usually translated "law," which suggests rules, regulations, and restrictions; better "instruction" for holiness—i.e., how to live in relationship to God in his world.

Fig. 2.1. Content of the Pentateuch by Book

Link each key event or figure with a Pentateuchal book: Genesis, Exodus, Leviticus, Numbers, Deuteronomy.	
Plagues	Exile from Garden
Creation Week	Wilderness wanderings
Battles with Og & Sihon	Blessings & curses
Water from the rock	Moses' death
Eve	Sacrifices
Tabernacle plans	Ten Commandments
Tower of Babel	7 good years, 7 bad
Call to love Yahweh	Battle with Amalekites
Call to love neighbor	Mount Sinai
Mount Moriah	Yahweh's Name
Talking donkey	Rainbow
Promises to Abraham	3 extended sermons
Exodus from Egypt	Golden calf

B. Narrative & Canonical Flow

1. Narrative Flow in the Pentateuch

Fig. 2.2. Narrative Flow in the Pentateuch

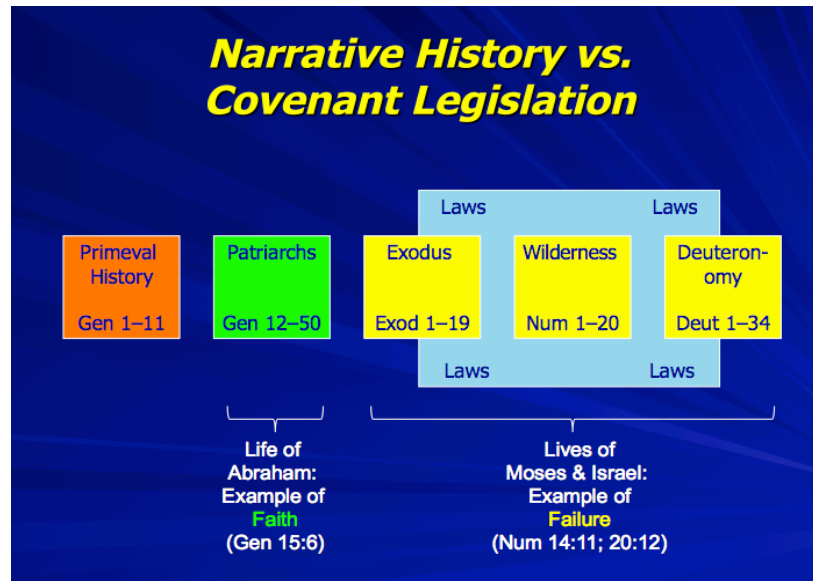

2. Canonical Flow in the Pentateuch: The Old Covenant Established in the Law (God as Savior)
 - a. Genesis: Prologue to God's Universal Kingdom
 - b. Exodus: King Yahweh and His Global Purpose through Israel
 - c. Leviticus: Holy Yahweh and the Necessity for Holiness
 - d. Numbers: Faithful Yahweh and His Unfaithful People
 - e. Deuteronomy: A Call to Lasting Covenant Relationship

C. Major Characters in the Plot:

1. Adam and Eve the first humans and Noah the preserver of the human race (Gen 2–11)
2. Abraham and his offspring, especially Jacob and Joseph (Gen 12–50)
3. Moses (Exod 1–Deut 34); *explains the covenant and leads Israel to the border of the promised land
4. Yahweh is the most dominant and ever present character; the Law first and foremost tells us about him

D. Component Parts:

1. Introduction: Gen 1:1–2:3
 - a. The formal narrative begins in 2:4.
 - b. The chapter provides an ideal lens for understanding how humans are to live in God's world God's way for God's glory.
 - c. Answers the key question being asked by the generation entering into Canaan (where the Pentateuch closes): How do I live and not die?
2. Central Concern:
 - a. Cluster of themes:
 - Supremacy of Israel's God as creator and sustainer

- Divine revelation in deed and word
 - Yahweh’s covenant with Israel in light of his covenants with Adam/Noah and Abraham
 - Abraham’s posterity climaxing in a single, male royal descendant
 - Divine election
 - Need for faith overflowing in obedience to enjoy life
 - Blessing and curses
- b. All related to the Kingdom of God—God, the Great King, grants to his obedient vassal the right to dwell in his land and promises sustained provision and protection from enemies, by which he will expand his worldwide kingdom.

Fig. 2.3. Component Parts of the Pentateuch

Introduction	Gen 1:1–2:3 – The chapter provides an ideal lens for understanding how humans are to live in God’s world, God’s way, for God’s glory; answers the key question being asked by the wilderness generation
Central Concern	Gen 2:4–Num 36:13 – The restoration and expansion of the Kingdom of God: the Yahweh-Israelite covenant becomes the lens for life for both Israel and the whole world.
Conclusion	Deuteronomy – the Constitution of the United Tribes of Israel for life in the land and for the fulfillment of God’s intentions for them as channels of kingdom expansion

E. The Development of “God’s Kingdom” in the Pentateuch:

1. Introductory comments:
 - a. The author wants to link God’s original plan of blessing for humanity with his establishment of the covenant with Israel at Sinai, which is God’s plan to restore his blessing to the world through the offspring of Abraham (Gen 12:1–3; Exod 2:24; 19:4–6).
 - b. The author wants to show that the covenant at Sinai will ultimately fail to restore God’s blessing to humanity because Israel will fail to trust God and obey his will.
 - c. The author wants to show that God’s promise to restore blessing will ultimately succeed because God himself will one day make possible in and through Israel what they cannot do on their own, thus giving God all the glory (Deut 30:1–10); he will do this through a single, male, royal redeemer who will also serve as God’s prophet of a new covenant.
 - d. The message of the Pentateuch is future oriented (eschatological) and focused on hope for the fulfillment of God’s worldwide kingdom expansion.
2. Progressive Movement in the Pentateuch toward a goal yet realized:
 - a. *Pentateuch* – Ends with a point of tension and expectation:
 - i. Israel has become a great people, but the Promised Land (the goal of the journey) has not yet been reached.
 - ii. Israel’s leader is dead.

- iii. Israel's future is open-ended: The previous generation failed to enter the Land; how will the new generation do?
 - b. *Genesis* – The deaths of Jacob (with his bones buried in Canaan) and Joseph (with the request that he be buried in Canaan once the conquest is complete) anticipate movement from Egypt to the Promised Land.
 - c. *Exodus* – Ends at Sinai (a stop in the journey) with the glory of Yahweh taking up residence in the movable tent, anticipating the journey that lies ahead.
 - d. *Leviticus and Numbers* – Shift from the commandment at Sinai (Lev 27:34) to the commandments given to the people in the plains of Moab by the Jordan at Jericho (Num 36:13) with narratives within regarding the movement toward the Land.
 - e. *Deuteronomy* – A statement principally directed toward the future: the “statutes and ordinances that you shall be careful to do in the land” (12:1).
3. Main theme: The fulfillment of the promises to the patriarchs to expand God's kingdom through a blessed, God-oriented community, as a reaffirmation of God's original intentions for the human race, through God's mercy and the collaboration of Moses

Fig. 2.4. Unity of the Pentateuch

Section	Theme
Genesis 1–11	The Need for Blessing (the curse)
Genesis 12–50	The Provision of Blessing (an heir)
Exodus–Leviticus	The Context for Blessing (the covenant)
Numbers–Deuteronomy	The Realm of Blessing (the land)
Central Thrust	God's covenant with his people is established
Main Theme	The fulfillment of the promises to the patriarchs to expand God's kingdom through a blessed, God-oriented community, as a reaffirmation of God's original intentions for the human race, through God's mercy and the collaboration of Moses.

II. Pentateuchal Authorship, Composition, and Historicity

Col 2:8. See to it that no one takes you captive by philosophy and empty deceit, according to human tradition, according to the elemental spirits of the world, and not according to Christ.

A. The Traditional View

1. The Pentateuch itself attests to Moses' composing at least some of its parts.
 - a. Moses wrote divine promises to instill faith:
 - Exod. 17:14. Then Yahweh said to Moses, “Write this as a memorial in a book and recite it in the ears of Joshua, that I will utterly blot out the memory of Amelek from under heaven.
 - b. Moses inscribed God's instructions to Israel as a lasting guide and warning:
 - Exod. 24:4; 34:27. And Moses wrote down all the words of Yahweh.... And Yahweh said to Moses, “Write these words, for in accordance with these words I have made a covenant with you and Israel.”
 - Deut. 31:24. When Moses had finished writing the words of this law in a book to the very end, he commanded the Levites who carried the ark of the Covenant of Yahweh,

- “Take this Book of the Law and put it by the side of the ark of the covenant of Yahweh your God, that it may be there for a witness against you.” (see 31:9)
- c. Moses journaled Israel’s journey through the wilderness
 - Num. 33:2. Moses wrote down their starting places, stage by stage, by command of Yahweh, and these are their stages according to their starting places.
 - d. Moses penned God’s warning song against Israel
 - Deut. 31:19, 22. Now therefore write this song and teach it to the people of Israel. Put it in their mouths, that this song may be a witness for me against the people of Israel.... So Moses wrote this song the same day and taught to the people of Israel.
2. Later biblical figures identify Moses with the Pentateuch, some even noting his authorship of its books.
- a. Titles used for all or part of the Pentateuch:
 - i. *The Book of Moses* (Ezra 6:18; Neh 13:1; 2 Chr 25:4; 35:12; Mark 12:26)
 - ii. *The Book of the Law* (Deut 29:21; 30:10; 31:26; Josh 1:8; 8:34; 2 Kgs 22:8, 11; 2 Chr 34:15; Neh 8:3; Gal 3:10); ... *of Moses* (Josh 8:31; 23:6; 2 Kgs 14:6; Neh 8:1); ... *of Yahweh* (Neh 9:3; 2 Chr 17:9; 34:14); of God (Neh 8:18)
 - iii. *The Law of Moses* (Josh 8:32; 1 Kgs 2:3; 2 Kgs 23:25; Dan 9:11, 13; Ezra 3:2; 7:6; 2 Chr 23:18; 30:16; Luke 2:2; 24:44; John 7:23; Acts 13:39; 15:5; 28:23; 1 Cor 9:9; Heb 10:28)
 - iv. *Moses* (Luke 24:27; cf. John 5:46–47)
 - v. *The testimony* (2 Kgs 11:12//2 Chr 23:11; cf. Exod 25:16; 31:18; 32:15, 29).
 - b. Key biblical voices:
 - i. The narrator of the Book of Joshua stresses Moses’ hand in writing.
 - Josh 8:32. And there, in the presence of the people of Israel, he wrote on the stones a copy of the law of Moses, *which he had written*.
 - ii. David speaks of a written Law associated with Moses.
 - 1 Kgs 2:3. Keep the charge of the LORD your God, walking in his ways and keeping his statutes, his commandments, his rules, and his testimonies, as it is written in the Law of Moses.
 - iii. The Chronicler stresses Moses was the channel through which the Book of the Law came.
 - 2 Chr 34:14. Hilkiyah the priest found the Book of the Law of the LORD *given through Moses*.
 - iv. Jesus unequivocally speaks of the Pentateuch in connection to Moses.
 - Luke 24:44. These are my words that I spoke to you while I was still with you, that everything written about me in *the Law of Moses* and the Prophets and the Psalms must be fulfilled.
 - v. Jesus explicitly declares that he is spoken about in Moses writings (pl).
 - John 5:46–47. If you believed Moses, you would believe me, for he wrote of me. But if you do not believe *his writings*, how will you believe my words?
3. Summary of Traditional View:
- a. Like all historical writing, the Pentateuchal narrative is selective and written from a particular viewpoint.
 - b. God is Lord of history.
 - c. The Pentateuch accurately records and interprets events from the creation through the death of Moses and provides a factual basis for Israel’s faith.

d. Moses was the primary author of the Pentateuch.

B. Some Challenges to the Traditional View

1. There are a number of editorial glosses that have led scholars to view the Pentateuch as having a late origin, from a time:
 - a. When the Canaanites were no longer a threat;
 - Gen. 12:6. Abram passed through the land to the place at Shechem, to the oak of Moreh. *At that time the Canaanites were in the land.* (see also 13:7)
 - b. When some would be ignorant of the origin of an Israelite practice;
 - Gen. 32:32. Therefore *to this day the people of Israel do not eat the sinew of the thigh that is on the hip socket, because he touched the socket of Jacob's hip on the sinew of the thigh.*
 - c. When the east side of the Jordan would be “beyond the Jordan”;
 - Deut. 1:5. *Beyond the Jordan, in the land of Moab, Moses undertook to explain this law....* (cf. 1:1; 3:8, 35; 4:41, 46–47, 49)
 - d. When some would need historical-geographical commentary on the origin of a city;
 - Deut. 3:14. Jair the Manassite took all the region of Argob, that is, Bashan, as far as the border of the Geshurites and the Maacathites, and called the villages after his own name, Havvoth-jair, *as it is to this day.*
 - e. When some would question the burial place of Moses;
 - Deut. 34:6. And he [Yahweh] buried him in the valley in the land of Moab opposite Beth-peor; *but no one knows the place of his burial to this day.*
 - f. When a comment about Moses' prophetic uniqueness would be significant.
 - Deut. 34:10. *And there has not arisen a prophet since in Israel like Moses.*
2. The Rise of Historical Higher Criticism (for a more fully developed discussion and evaluation of historical higher criticism, see Appendix 2.1, “Pentateuchal Criticism”):
 - a. Historical criticism relates to the various approaches to biblical interpretation that assess the date, authorship, composition, and literary boundaries of ancient texts. Historical *higher* criticism found its roots in the post-Enlightenment world of the 18th and 19th centuries and found greatest definition at the end of the 19th century, being guided by three fundamental presuppositions (E. Troeltsch, 1865–1923):
 - i. *Principle of Criticism*: presupposed skepticism of sources
 - ii. *Principle of Analogy*: present human experience limits what can qualify as “historical” in the past
 - iii. *Principle of Correlation*: When two events correlate, we must limit potential historical causation to either natural forces or human agency.
 - b. The presuppositions were accompanied by a series of methodological assumptions that had a massive impact on the interpretation of the Pentateuch:
 - i. It is easy to determine the purposes and methods behind documents and redactions.
 - ii. Civilization and religion progress slowly, and Israel's history, literature, and religion developed in a simple, evolutionary manner. A great work of literature like the Pentateuch could not have been written in the 2nd millennium B.C.; indeed, Greek epic and dramatic literature did not appear until 1st millennium. Furthermore, Israelite history and

- religion must have progressed from primitive tribal religion to prophetic ethical religion to advanced monotheism (animism > polytheism > henotheism > monotheism).
- iii. Inter-textual markers or stylistic differences allow us to delineate source divisions in a text, resulting in the identification of four separate source documents in the Pentateuch: Yahwehistic source (J) > Elohist source (E) > Deuteronomy (D) > Priestly source (P).
 - iv. The individual authors of the various sources aimed to produce a single, continuous history but would not tolerate inconsistency, repetition, or narrative digressions; the redactors, on the other hand, were oblivious to and/or comfortable with contradiction and repetition when they combined their documents.
 - v. D assumed JE but not P, the latter of which revealed a developed monotheism not seen in Israel's early national history. P must therefore be the latest source, and the Pentateuch must not have been completed in its present form until the post-exilic period.
- c. As noted, at the end of the 19th century, historical higher critics believed that inter-textual markers within Genesis–Joshua signalled four independent, continuous, single narrative sources from Genesis to Joshua (JEDP) that only later were brought together and edited into the present work. The key inter-textual markers that guided the divisions were:
- i. Different names for the deity (cf. J. Astruc)
 - (1) Yahweh: the mark of the Yahwistic / J source (Gen. 2–3)
 - (2) Elohim: the mark of the Elohist / E source (Gen. 15:1–3)
 - (3) El-Shaddai: the mark of the Priestly / P source (Gen. 17:1; Exod 6:2)
 - ii. Variations in language and style
 - (1) Certain words / forms tend to appear where one or the other divine name predominates:

Yahwistic (J) Source	Elohist (E) Source
Sinai	Horeb
Canaanites	Amorites
Reuel / Hobab	Jethro
Yahweh	Elohim
God made (formally, “cut”) a covenant	God established a covenant

- (2) Some are fast moving, vivid, pictorial, well crafted stories (esp. J); but others are dull, tedious, wordy, formal, technical, often concerned with issues of genealogy (esp. P) or legal matters (esp. P or D).
- iii. “Contradictions” and divergences in view
 - (1) In the flood story, Gen. 6:11–22 (P) says to take two of every kind of animal, but Gen. 7:1–5 (J) says to take seven pairs of clean animals.
 - (2) In D all Levites are priests, whereas in P (esp. P portions of Exod and Lev) only the Aaronides are called priests and the rest of the Levites are mere temple workers without priestly privileges.

- (3) God can be presented in almost human form and passion (anthropomorphically), but he can also be pictured as distant, removed from human beings and revealing himself only through impersonal dreams and angelic messengers.
 - (4) People approach God through prayer and moral decision, but they also approach him through sacrifice and ritual.
 - (5) Israelite heroes are presented inconsistently, their faults being either frankly presented (e.g., Jacob the cheat) or toned down and passed over (e.g., Abraham the man of faith).
- iv. Duplicate accounts and / or repetitions
- (1) Side by side juxtapositioning: P (Gen. 1:1–2:3) / J (Gen. 2:4–3:24)
 - (2) Single incident distributed in different contexts and understood as separate events:
 - (a) Passing off the Wives as Sisters: Abraham (Gen. 12:10–20 [J]; 20:1–18 [E]); Isaac (Gen. 26:6–11)
 - (b) The Naming of Beersheba: Abraham (Gen. 21:31); Isaac (Gen. 26:33)
 - (3) The interweaving of separate strands, creating the appearance of a single account, though with each “source” having its own unity of theology and message (so Bruegemann and Wolff, *The Vitality of Old Testament Tradition* [Atlanta: John Knox, 1975]) (e.g., the flood account according to B. W. Anderson, *Understanding the Old Testament*, 2nd ed., p. 165 [see next page]):

6:10–22	P	7:12	J	8:1–2a	P	8:13b	J	9:28–27	P
7:1–5	J	7:13–16a	P	8:2b–3a	J	8:14–19	P		
7:6	P	7:16b–17	J	8:3b–5	P	8:20–22	J		
7:7–10	J	7:18–21	P	8:6–12	J	9:1–17	P		
7:11	P	7:22	J	8:13a	P	9:18–27	J		

Fig. 2.5. The Genesis Flood Accounts according to One Version of the Documentary Hypothesis

*As proposed by B. W. Anderson, *Understanding the Old Testament*, 2nd ed., p. 165; prepared by Jason S. DeRouchie (2010)

<i>The Priestly Account of the Flood</i>	<i>The Yahwistic Account of the Flood</i>
<p>6:10And Noah had three sons, Shem, Ham, and Japheth. 11Now the earth was corrupt in God’s sight, and the earth was filled with violence. 12And God saw the earth, and behold, it was corrupt, for all flesh had corrupted their way on the earth. 13And God said to Noah, “I have determined to make an end of all flesh, for the earth is filled with violence through them. Behold, I will destroy them with the earth. 14Make yourself an ark of gopher wood. Make rooms in the ark, and cover it inside and out with pitch. 15This is how you are to make it: the length of the ark 300 cubits, its breadth 50 cubits, and its height 30 cubits. 16Make a roof for the ark, and finish it to a cubit above, and set the door of the ark in its side. Make it with lower, second, and third decks. 17For behold, I will bring a flood of waters upon the earth to destroy all flesh in which is the breath of life under heaven. Everything that is on the</p>	<p>7:1Then the LORD said to Noah, “Go into the ark, you and all your household, for I have seen that you are righteous before me in this generation. 2Take with you seven pairs of all clean animals, the male and his mate, and a pair of the animals that are not clean, the male and his mate, 3and seven pairs of the birds of the heavens also, male and female, to keep their offspring alive on the face of all the earth. 4For in seven days I will send rain on the earth forty days and forty nights, and every living thing that I have made I will blot out from the face of the ground.” 5And Noah did all that the LORD had commanded him... 7And Noah and his sons and his wife and his sons’ wives with him went into the ark to escape the waters of the flood. 8Of clean animals, and of animals that are not clean, and of birds, and of everything that creeps on the ground, 9two and two, male and female, went into the ark</p>

earth shall die. ¹⁸But I will establish my covenant with you, and you shall come into the ark, you, your sons, your wife, and your sons' wives with you. ¹⁷And of every living thing of all flesh, you shall bring two of every sort into the ark to keep them alive with you. They shall be male and female. ²⁰Of the birds according to their kinds, and of the animals according to their kinds, of every creeping thing of the ground, according to its kind, two of every sort shall come in to you to keep them alive. ²¹Also take with you every sort of food that is eaten, and store it up. It shall serve as food for you and for them." ²²Noah did this; he did all that God commanded him....

^{7:6}Noah was six hundred years old when the flood of waters came upon the earth....

¹¹In the six hundredth year of Noah's life, in the second month, on the seventeenth day of the month, on that day all the fountains of the great deep burst forth, and the windows of the heavens were opened....

¹³On the very same day Noah and his sons, Shem and Ham and Japheth, and Noah's wife and the three wives of his sons with them entered the ark, ¹⁴they and every beast, according to its kind, and all the livestock according to their kinds, and every creeping thing that creeps on the earth, according to its kind, and every bird, according to its kind, every winged creature. ¹⁵They went into the ark with Noah, two and two of all flesh in which there was the breath of life. ^{16a}And those that entered, male and female of all flesh, went in as God had commanded him....

¹⁸The waters prevailed and increased greatly on the earth, and the ark floated on the face of the waters. ¹⁹And the waters prevailed so mightily on the earth that all the high mountains under the whole heaven were covered. ²⁰The waters prevailed above the mountains, covering them fifteen cubits deep. ²¹And all flesh died that moved on the earth, birds, livestock, beasts, all swarming creatures that swarm on the earth, and all mankind....

^{8:1}But God remembered Noah and all the beasts and all the livestock that were with him in the ark. And God made a wind blow over the earth, and the waters subsided. ^{2a}The fountains of the deep and the windows of the heavens were closed....

^{3b}At the end of 150 days the waters had abated, ⁴and in the seventh month, on the seventeenth day of the month, the ark came to rest on the mountains of Ararat. ⁵And the waters continued to abate until the tenth month; in the tenth month, on the first day of the month, the tops of the mountains were seen....

^{13a}In the six hundred and first year, in the first month, the first day of the month, the waters were dried from off the earth....

¹⁴In the second month, on the twenty-seventh day of the month, the earth had dried out. ¹⁵Then God said to Noah, ¹⁶"Go out from the ark, you and your wife, and your sons and your sons' wives with you. ¹⁷Bring out with you every living thing that is with you of all flesh—birds and animals and every creeping thing that creeps on the earth—that they may swarm on the earth, and be fruitful and multiply on the earth." ¹⁸So Noah went out, and his sons and his wife and his sons' wives with him. ¹⁹Every beast, every creeping thing, and every bird, everything

with Noah, as God had commanded Noah. ¹⁰And after seven days the waters of the flood came upon the earth....

¹²And rain fell upon the earth forty days and forty nights....

^{16b}And the LORD shut him in. ¹⁷The flood continued forty days on the earth. The waters increased and bore up the ark, and it rose high above the earth....

²²Everything on the dry land in whose nostrils was the breath of life died....

^{8:2b}The fountains of the deep and the windows of the heavens were closed, the rain from the heavens was restrained, ^{3a}and the waters receded from the earth continually....

⁶At the end of forty days Noah opened the window of the ark that he had made ⁷and sent forth a raven. It went to and fro until the waters were dried up from the earth. ⁸Then he sent forth a dove from him, to see if the waters had subsided from the face of the ground. ⁹But the dove found no place to set her foot, and she returned to him to the ark, for the waters were still on the face of the whole earth. So he put out his hand and took her and brought her into the ark with him. ¹⁰He waited another seven days, and again he sent forth the dove out of the ark. ¹¹And the dove came back to him in the evening, and behold, in her mouth was a freshly plucked olive leaf. So Noah knew that the waters had subsided from the earth. ¹²Then he waited another seven days and sent forth the dove, and she did not return to him anymore....

^{13b}And Noah removed the covering of the ark and looked, and behold, the face of the ground was dry....

²⁰Then Noah built an altar to the LORD and took some of every clean animal and some of every clean bird and offered burnt offerings on the altar. ²¹And when the LORD smelled the pleasing aroma, the LORD said in his heart, "I will never again curse the ground because of man, for the intention of man's heart is evil from his youth. Neither will I ever again strike down every living creature as I have done. ²²While the earth remains, seedtime and harvest, cold and heat, summer and winter, day and night, shall not cease."...

^{9:18}The sons of Noah who went forth from the ark were Shem, Ham, and Japheth. (Ham was the father of Canaan.) ¹⁹These three were the sons of Noah, and from these the people of the whole earth were dispersed. ²⁰Noah began to be a man of the soil, and he planted a vineyard. ²¹He drank of the wine and became drunk and lay uncovered in his tent. ²²And Ham, the father of Canaan, saw the nakedness of his father and told his two brothers outside. ²³Then Shem and Japheth took a garment, laid it on both their shoulders, and walked backward and covered the nakedness of their father. Their faces were turned backward, and they did not see their father's nakedness. ²⁴When Noah awoke from his wine and knew what his youngest son had done to him, ²⁵she said, "Cursed be Canaan; a servant of servants shall he be to his brothers." ²⁶He also said, "Blessed be the LORD, the God of Shem; and let Canaan be his servant. ²⁷May God enlarge Japheth, and let him dwell in the tents of Shem, and let Canaan be his servant."

that moves on the earth, went out by families from the ark....

^{9:1}And God blessed Noah and his sons and said to them, "Be fruitful and multiply and fill the earth. ²The fear of you and the dread of you shall be upon every beast of the earth and upon every bird of the heavens, upon everything that creeps on the ground and all the fish of the sea. Into your hand they are delivered. ³Every moving thing that lives shall be food for you. And as I gave you the green plants, I give you everything. ⁴But you shall not eat flesh with its life, that is, its blood. ⁵And for your lifeblood I will require a reckoning: from every beast I will require it and from man. From his fellow man I will require a reckoning for the life of man. ⁶"Whoever sheds the blood of man, by man shall his blood be shed, for God made man in his own image. ⁷And you, be fruitful and multiply, teem on the earth and multiply in it." ⁸Then God said to Noah and to his sons with him, ⁹"Behold, I establish my covenant with you and your offspring after you, ¹⁰and with every living creature that is with you, the birds, the livestock, and every beast of the earth with you, as many as came out of the ark; it is for every beast of the earth. ¹¹I establish my covenant with you, that never again shall all flesh be cut off by the waters of the flood, and never again shall there be a flood to destroy the earth." ¹²And God said, "This is the sign of the covenant that I make between me and you and every living creature that is with you, for all future generations: ¹³I have set my bow in the cloud, and it shall be a sign of the covenant between me and the earth. ¹⁴When I bring clouds over the earth and the bow is seen in the clouds, ¹⁵I will remember my covenant that is between me and you and every living creature of all flesh. And the waters shall never again become a flood to destroy all flesh. ¹⁶When the bow is in the clouds, I will see it and remember the everlasting covenant between God and every living creature of all flesh that is on the earth." ¹⁷God said to Noah, "This is the sign of the covenant that I have established between me and all flesh that is on the earth." ...

²⁸After the flood Noah lived 350 years. ²⁹All the days of Noah were 950 years, and he died.

v. Anachronisms (i.e., chronological lapses)

- (1) References to the Philistines (Gen. 21:32; 26:1–18), who came to Palestine only after the time of Moses.
- (2) Gen. 14:14 calls northernmost Palestine "Dan," a designation that only arose during the settlement period.
- (3) References to Ur of the "Chaldees" (Gen. 11:28; 15:7), an ethnic group that does not appear in Mesopotamia until 1000 B.C.
- (4) Camels (Gen. 24:10–14; 31:17) were supposedly not domesticated until ca. 1000 B.C.
- (5) Expressions like "before any king reigned over the Israelites" (Gen. 36:31) and "Canaanites were then in the land" (Gen. 12:6; 13:7) assume a king reigns and Canaanites are absent at the time of writing.

vi. Textual references to Moses

- (1) He is referred to throughout in 3rd person.
 - (2) Specific portions are attributed to him, so that the exceptions obviously prove the rule.
 - (a) Exod 17:4—the curse of Amelek
 - (b) Exod 24:4—the laws at Sinai
 - (c) Num 33:2—Israel’s itinerary in the desert
 - (3) His death is recorded.
- d. The implications of historical higher criticism of the Pentateuch:
- i. No miracles or foretelling of the future: The supernatural realities expressed in the Pentateuch are beyond validation (thus unscientific) and therefore unhistorical.
 - ii. The belief that God is the Lord of history is unscientific and thus unhistorical.
 - iii. Developed beliefs come only by a long process of evolution.
 - (1) The movement is always from naturalistic animism > polytheism > henotheism > monotheism.
 - (2) The developed theology (monotheism + detailed laws) of the Pentateuch requires a long evolution in Israel’s history, suggesting the Pentateuch is a late creation grounded in myth and fiction, though filled with hope and moral teaching.
 - (a) Primitive, simple, spontaneous, popular faith > ethical concerns and consciousness initiated by the prophets > ceremonial and ritual religion (“law”) influenced by the priests.
 - (b) Various “sources” must, therefore, have been redacted into what we now have as the Pentateuch: J (“Yahwistic Source”); E (“Elohistic Source”); P (“Priestly Source”); D (“Deuteronomy”)

J (900B.C.) > E (800) > R ^{JE} (650) > D (621) > R ^{JED} (550) > P (450) > R ^{JEDP} (400)
--

- (i) J=ca. 900 (1000–840) B.C.: J was written by someone from Judah who emphasized biography as well as ethical and religious concerns. It uses the name Yahweh, and is often considered the original thinker who gave shape to the OT idea of the history of salvation.
- (ii) E=ca. 800 (900–700) B.C.: E came from the northern kingdom and displayed more objectivity in his narrative style. It uses the title Elohim, as the name Yahweh was not revealed until Exod 3:15 (E). E is more sensitive to moral issues than J, but God is viewed as more distant from man.
- (iii) R^{JE}=ca. 700–650 B.C.: JE were brought together by a redactor. More than a compiler of document, RJE (the Yahwist) was an author (e.g., Sinai pericope) who

created a seamless narrative. J formed the basetext, and much of E was redacted out.

- (iv) D=ca. 621 B.C.: D was the book “discovered” and probably written by Hilkiyah the high priest during Josiah’s “reforms.” It incorporated a number of exhortations and laws that may have been a reaction to the wicked reign of Manasseh. D uses both Yahweh and Elohim.
 - (v) R^{JED}=ca. 550 B.C.: D was linked with JE by a redactor (RJED), who himself made a few D insertions into the JE narrative.
 - (vi) P=ca. 550–450 B.C.: Significantly post-exilic, P consisted of legal and ceremonial material compiled primarily by Ezra. It represents the triumph of the post-exilic priesthood and attempts to justify their form of worship and codify their religion. In Genesis P refers to God as Elohim, because it assumes with E that the divine name Yahweh was first revealed later (cf. Exod 6:3 [P]). It is dominated by genealogies priestly regulations, and very formal narration. The Holiness Code (Lev 18–26) was composed by Ezekiel and incorporated into P by Ezra. That JED antedates P is suggested by Deuteronomy’s awareness of JE material but not P material.
 - (vii) R^{JEDP}=ca. 450–200 B.C.: P was combined with JED to form a continuous narrative, making the Hexateuch complete.
- iv. By 1970, a scholarly consensus emerged that affirmed:
- (1) General agreement on sources.
 - (2) The final form has a pre-history that can serve to enlighten the history of Israel.
 - (3) Developmentalism/evolution (animism > polytheism > henotheism > monotheism)

Fig. 2.6. The Documentary Hypothesis by 1970

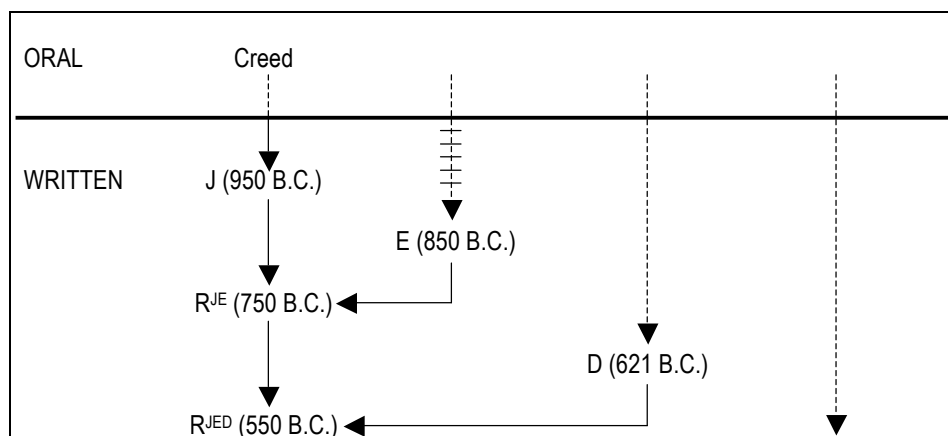



- e. The results of historical higher criticism of the Pentateuch: The OT cannot speak for itself but must be re-conceptualized (from Garrett, “Historical Criticism,” in *Foundations for Biblical Interpretation*, p. 193):
 - i. Most today reject Mosaic authorship.
 - ii. Most today affirm that the stories in the Pentateuch likely differ radically from the early material behind the text (i.e., whether earlier sources or what actually happened).
 - iii. Most last century and some today believe the Pentateuchal text resulted from a long process of joining and editing material that was often contradictory and had little connection with Moses.
 - iv. Most today see the Pentateuch as a unified work void of long redaction or tradition histories; however, the same scholars tend to treat the text as out-and-out fiction with little or no historical moorings and having a very late provenance in the history of Israel.

C. An Initial Response to the Challenges Related to the Pentateuch’s Authorship and Composition (for a more thorough overview of the history of this discussion with evaluation, see Appendix A.2.1 and A.2.2.)

1. Introduction:
 - a. Duane Garrett has rightfully asserted, “If the [documentary] hypothesis is true, then the Pentateuch is essentially fiction. Worse than that, it is a confused self-contradictory fiction with no unified theological message.”¹
 - b. The goal of determining the beginning and ending of a literary unit is both legitimate and necessary, for the chapter and verse divisions in the Bible are not always reliable indicators of the boundaries of literary units.
 - c. The goal of identifying sources incorporated into a text is not bad in and of itself, for sources are the backbone of books. We know the writers of Scripture often used sources (cf. e.g., 1 Chr 29:29; 2 Chr 9:29; Luke 1:1–4), and there is also clear evidence that composition at times took place in several stages (e.g., Psalms and Proverbs).
 - d. The challenge with historical higher criticism (= source criticism) as portrayed above relates to the nature of these sources and the stages of development.
2. The unhelpful presuppositions of historical higher criticism. These principles of criticism, analogy, and correlation are nothing more than assumptions about the nature of reality—i.e., statements of faith. All worldviews are a web of interconnected beliefs about reality, and such beliefs can be theistic or a-theistic, Christian or anti-Christian, but all are nevertheless faith-based. What is needed is a reshaping of the principles of criticism that allows for the possibility of God.

Fig. 2.7. Redefining the Canons of Historical Criticism

¹ Garrett, “The Undead Hypothesis,” 29.

	<i>A-Theological</i>	<i>Theological</i>
Principle of Criticism	Presupposed skepticism about sources	Thoughtful appraisal of the evidence in keeping with its source
Principle of Analogy	Present human experience limits what can qualify as "history"	Historical plausibility is judged by the reasonableness of arguments made for belief in occurrences with which the historian may have no personal acquaintance
Principle of Correlation	When assessing the relationship of correlated events, potential historical causation must be limited to natural forces or human agency	Allow for <i>personal</i> and not just natural or material forces in causation

*Taken from W. J. Abraham, *Divine Revelation and the Limits of Historical Criticism* (Oxford, 1982).

3. The false assumptions of source analysis (some sample responses):²
 - a. While source criticism sometimes results in the delineation of discrete, well-shaped units that stand on their own, the result more often is internal confusion in each "document" that does not hold clearly together. An example is found in S. R. Driver's proposed source divisions of Genesis 28:10–30:7 (*An Introduction to the Literature of the Old Testament*, 16) (see next page). While some may respond that details that would make the J and E versions more coherent have been suppressed in the redactional process, this only concedes the point that J and E, as we have them, are incoherent and cannot be used to support the documentary hypothesis.

Fig. 2.8. The Genesis Accounts of Jacob's Dream and Marriages according to One Version of the Documentary Hypothesis

*As proposed by S. R. Driver, *An Introduction to the Literature of the Old Testament*, 16; prepared by Jason S. DeRouchie (2010).

<i>The Yahwistic Account</i>	<i>The Elohist Account</i>
<p>^{28:10}Jacob left Beersheba and went toward Haran....</p> <p>¹³And behold, the LORD stood above it and said, "I am the LORD, the God of Abraham your father and the God of Isaac. The land on which you lie I will give to you and to your offspring. ¹⁴Your offspring shall be like the dust of the earth, and you shall spread abroad to the west and to the east and to the north and to the south, and in you and your offspring shall all the families of the earth be blessed. ¹⁵Behold, I am with you and will keep you wherever you go, and will bring you back to this land. For I will not leave you until I have done what I have promised you." ¹⁶Then Jacob awoke from his sleep and said, "Surely the LORD is in this place, and I did not know it."...</p> <p>¹⁹He called the name of that place Bethel, but the name of the city was Luz at the first.... [[The text now jumps to Haran without any notice, but the reader of J may think that he is naming some site in Haran "Bethel."]]</p> <p>^{29:2}As he looked, he saw a well in the field, and behold, three flocks of sheep lying beside it, for out of that well the</p>	<p>^{28:11}And he came to a certain place and stayed there that night, because the sun had set. Taking one of the stones of the place, he put it under his head and lay down in that place to sleep. ¹²And he dreamed, and behold, there was a ladder set up on the earth, and the top of it reached to heaven. And behold, the angels of God were ascending and descending on it!...</p> <p>¹⁷And he was afraid and said, "How awesome is this place! This is none other than the house of God, and this is the gate of heaven." ¹⁸So early in the morning Jacob took the stone that he had put under his head and set it up for a pillar and poured oil on the top of it.... [[In what follows, Jacob deduces that the deity in his dream was Yahweh and assumes God's presence with him even though he receives no covenant promises; note also the use of "Yahweh" in E.]]</p> <p>²⁰Then Jacob made a vow, saying, "If God will be with me and will keep me in this way that I go, and will give me bread to eat and clothing to wear, ²¹so that I come again to my father's house in peace, then the LORD shall be my God, ²²and</p>

² Some of this material is adapted from Block, "Introduction to the Old Testament—Part 1," 23–27; Garrett, "The Undead Hypothesis," 32–39.

<p>flocks were watered. The stone on the well's mouth was large,³ and when all the flocks were gathered there, the shepherds would roll the stone from the mouth of the well and water the sheep, and put the stone back in its place over the mouth of the well.⁴ Jacob said to them, "My brothers, where do you come from?" They said, "We are from Haran."⁵ He said to them, "Do you know Laban the son of Nahor?" They said, "We know him."⁶ He said to them, "Is it well with him?" They said, "It is well; and see, Rachel his daughter is coming with the sheep!"⁷ He said, "Behold, it is still high day; it is not time for the livestock to be gathered together. Water the sheep and go, pasture them."⁸ But they said, "We cannot until all the flocks are gathered together and the stone is rolled from the mouth of the well; then we water the sheep."⁹ While he was still speaking with them, mRachel came with her father's sheep, for she was a shepherdess.¹⁰ Now as soon as Jacob saw Rachel the daughter of Laban his mother's brother, and the sheep of Laban his mother's brother, Jacob came near and rolled the stone from the well's mouth and watered the flock of Laban his mother's brother.¹¹ Then Jacob kissed Rachel and wept aloud.¹² And Jacob told Rachel that he was her father's kinsman, and that he was Rebekah's son, and she ran and told her father.¹³ As soon as Laban heard the news about Jacob, his sister's son, he ran to meet him and embraced him and kissed him and brought him to his house. Jacob told Laban all these things,¹⁴ and Laban said to him, "Surely you are my bone and my flesh!" And he stayed with him a month.... [[The text now switches to a discussion of Jacob's wives, without ever telling us who Leah is or that he married Leah and Rachel.]]</p> <p>³¹When the LORD saw that Leah was hated, he opened her womb, but Rachel was barren.³² And Leah conceived and bore a son, and she called his name Reuben, for she said, "Because the LORD has looked upon my affliction; for now my husband will love me."³³ She conceived again and bore a son, and said, "Because the LORD has heard that I am hated, he has given me this son also." And she called his name Simeon.³⁴ Again she conceived and bore a son, and said, "Now this time my husband will be attached to me, because I have borne him three sons." Therefore his name was called Levi.³⁵ And she conceived again and bore a son, and said, "This time I will praise the LORD." Therefore she called his name Judah. Then she ceased bearing.... [[Now the voice of the main character switches to Rachel without notice of the shift, and no clarity is offered as to whom Bilhah is serving as a surrogate mother; we don't even know Rachel is Jacob's second wife!]]</p> <p>^{30:3b} "That even I may have children through her."⁴ So she gave him her servant Bilhah as a wife, and Jacob went in to her.⁵ And Bilhah conceived and bore Jacob a son....⁷ Rachel's servant Bilhah conceived again and bore Jacob a second son.</p>	<p>this stone, which I have set up for a pillar, shall be God's house. And of all that you give me I will give a full tenth to you."^{29:1} Then Jacob went on his journey and came to the land of the people of the east.... [[Laban now begins to speak without ever being introduced.]]</p> <p>¹⁵Then Laban said to Jacob, "Because you are my kinsman, should you therefore serve me for nothing? Tell me, what shall your wages be?"¹⁶ Now Laban had two daughters. The name of the older was Leah, and the name of the younger was Rachel.¹⁷ Leah's eyes were weak, but Rachel was beautiful in form and appearance.¹⁸ Jacob loved Rachel. And he said, "I will serve you seven years for your younger daughter Rachel."¹⁹ Laban said, "It is better that I give her to you than that I should give her to any other man; stay with me."²⁰ So Jacob served seven years for Rachel, and they seemed to him but a few days because of the love he had for her.²¹ Then Jacob said to Laban, "Give me my wife that I may go in to her, for my time is completed."²² So Laban gathered together all the people of the place and made a feast.²³ But in the evening he took his daughter Leah and brought her to Jacob, and he went in to her....</p> <p>²⁵And in the morning, behold, it was Leah! And Jacob said to Laban, "What is this you have done to me? Did I not serve with you for Rachel? Why then have you deceived me?"²⁶ Laban said, "It is not so done in our country, to give the younger before the firstborn.²⁷ Complete the week of this one, and we will give you the other also in return for serving me another seven years."²⁸ Jacob did so, and completed her week. Then Laban gave him his daughter Rachel to be his wife....</p> <p>³⁰So Jacob went in to Rachel also, and he loved Rachel more than Leah, and served Laban for another seven years.... [[The transition to Rachel's child-bearing challenges that follows is somewhat abrupt, and we are never told that Leah had bore children that could have caused Rachel's jealousy.]]</p> <p>^{30:1}When Rachel saw that she bore Jacob no children, she envied her sister. She said to Jacob, "Give me children, or I shall die!"² Jacob's anger was kindled against Rachel, and he said, "Am I in the place of God, who has withheld from you the fruit of the womb?"^{3a} Then she said, "Here is my servant Bilhah; go in to her, so that she may give birth on my behalf...." [[In the verse that follows, Rachel praises God for a son, but the text is not clear who bore the son—Rachel or Bilhah.]]</p> <p>⁶Then Rachel said, "God has judged me, and has also heard my voice and given me a son." Therefore she called his name Dan.</p>
<p>Later editorial additions:</p> <p>^{29:24} Laban gave his female servant Zilpah to his daughter Leah to be her servant.</p> <p>²⁹ Laban gave his female servant Bilhah to his daughter Rachel to be her servant.</p>	

- b. R. N. Whybray has perceptively identified a challenge to the deconstructionist approach employed by traditional source critics (*The Making of the Pentateuch: A Methodological Study*, JSOTSup 53 [Sheffield: JSOT, 1999], 49): "The identification and reconstruction of the documents

were based on the assumption that each document was consistent with itself, in language, style and theology or points of view. Without this concept of consistency the hypothesis would fall to the ground. Yet the hypothesis depends equally, on the concept of the *inconsistency* apparent in the larger works which are supposed to be the work of the redactors: that is to say, the actual distinction made by the critics between one passage or phrase and another as having originally belonged to different documents is made on the basis of the redactor's having left two conflicting passages or phrases side by side with no attempt to conceal their incompatibility. Thus the hypothesis can only be maintained on the assumption that, while consistency was the hallmark of the various documents, *inconsistency* was the hallmark of the redactors."³

- c. Different names for Deity
- i. The variations are intentional because each name has a unique significance (e.g., Yahweh, the covenantal personal name of God; Elohim, the universal, cosmic God; El-shadai: the one who presides over the heavenly court)
 - ii. Other nations used more than one name for their gods (e.g., Baal = Aleyn Baal = Son of Dagon, etc.), so why should Israel not be allowed this practice?
 - iii. The distinctions are not maintained consistently:
 - (1) Genesis 2–4 is traditionally assigned to J, but in it we read not only “Yahweh” but “Yahweh Elohim.”
 - (2) Genesis 22:11 is traditionally assigned to E, but it uses “Yahweh.”
 - (3) E and P both use Elohim.
 - iv. Since the names are used interchangeably elsewhere, the alteration may be unconscious, or it may be that the use of one title over another bears theological significance (e.g., in the Jacob narrative where he only used Elohim until he meets God and then uses Yahweh).
 - v. There is no legitimate reason why the proposed sources would have refrained from using the different names. No one questions that J knew the word Elohim, and no one has proposed theological reasons why J would have avoided it. Similarly, while some propose that E and P writers thought that Israelites did not know of the divine name Yahweh until the time of Moses (a conclusion based on faulty exegesis of Gen. 4:26; Exod. 3:13–15; 6:24), there is no reason for them to avoid using the name in patriarchal stories except when they were directly quoting a character whom they believed did not yet know the name. Indeed, we would expect P to use Yahweh in his patriarchal narrative in order to establish continuity with the Exodus.

³ A follower of the classic Documentary Hypothesis in some form, Kenton L. Sparks asserts that the final editor of the Pentateuch “so valued tradition, and was so fixed on collecting these sources, that he or she did not care (or did not care much) about whether the traditions fit together nicely” (“Genesis 1–11 as Ancient Historiography,” in *Genesis: History, Fiction, or Neither?*, ed. Charles Halton, Counterpoints [Grand Rapids: Zondervan, 2015], 137). In my view, this approach is unconvincing and results in the sweeping away of biblical authority.

- d. Variations in language and style
 - i. Style depends on context and is not a mark of authorship. One person is capable of writing many different types of material. Shakespeare wrote sonnets, tragedies, comedies, and prose.
 - ii. The alteration of words may be purely stylistic for the sake of variation, or it may be due to distinct nuances of meaning, even unknown to us.
 - iii. The “arid” style of the genealogies of P is simply a by-product of their nature as genealogies and has nothing to do with their being written in a different style. Furthermore, the genealogies of J look just like those of P.
- e. “Contradictions” and divergences in view
 - i. General note: Every “contradiction” has to be examined on a case-by-case basis, but apparent contradictions hardly sustain the documentary hypothesis. The key teaching of the passages must be emphasized. Inconsistencies can be forced on anybody’s writing if one is determined to do so.
 - ii. *Inconsistencies in the flood account*. Whereas Genesis 6:20 calls for one pair of every kind of animal to be brought on the ark, 7:2 says to bring seven pairs of clean animals. This difference is easily explained if 7:1–2 provides the precise figure given immediately before the flood, whereas 6:20 is a general figure given before the ark was built. Provision had to be made to ensure that there would be sufficient livestock after the flood, and thus the higher number of clean animals.
 - iii. *The inconsistent use of the term Levite*. The solution is best explained within the context of the history of Israel as it is traditionally and canonically understood (see Garrett, *Rethinking Genesis*, ch. 11).
 - iv. *Distinct portraits of God*. God is not a stone. He adapts his methods to meet the needs of people and circumstances.
 - v. *Different means of worship*. The view that approaching God by prayer stands in contrast to approaching him by ritual is highly subjective. Both are true and not contradictory.
 - vi. *Human faults*. The Bible is the most honest book of antiquity. Where it appears to tone down faults in descriptive material, the prescriptive texts must still serve as the norms for proper behavior.
- f. Duplicate accounts and / or repetitions
 - i. General comments:
 - (1) In an ancient text, there is no stronger indication that a single document is present than parallel accounts. For example, in the Ugaritic Epic of Keret, large portions of the text are repeated verbatim (albeit from different perspectives). Similarly, in Genesis 24, a great deal of vv. 12–27 is repeated in vv. 34–48, albeit from the servant’s perspective.
 - (2) If two or more separate events were perceived to be similar to one another, ancient writers tended to give accounts of the events in parallel fashion, highlighting the similarities. In Kings, for

- example, a common formula is used of all northern kings to highlight their common evil in departing from Yahweh.
- ii. Creation
 - (1) Genesis 2 does not claim to duplicate Genesis 1 as a description of the creation of the world. Rather, Genesis 2 may be interpreted as a complementary exposition that officially begins the narrative history that runs all the way to the end of Ezra-Nehemiah. Genesis 1:1–2:3 is a foundation introduction to the whole, introducing the biblical worldview in light of initial creation.
 - (2) Even if Genesis 2 is repetitious at points, the technique of recapitulation was common to all Semites.
 - iii. The naming of Beersheba
 - (1) The details of the two accounts in Genesis 21:31 and 26:33 are actually different.
 - (2) Genesis 26 may well be seen as a covenant renewal.
 - (3) In Genesis 21, Abimelech seizes the well, which is not so in ch. 26.
 - (4) Abimelech and Phicol could be the same men, with one or both of the “names” being official titles rather than personal names.
 - (5) Abraham was an old man in ch. 21. Isaac also needs a well, and therefore, he renews the covenant.
 - (6) In Genesis 26:17 the wells are filled up by the Philistines; Isaac does need to reclaim them.
 - g. Signs of composite structure—the flood:
 - i. An unbiased reader does not recognize the fine distinctions proposed by the document critics.
 - ii. Nothing of that which is attributed to J is incompatible with P.
 - iii. Whereas Genesis 6:10–22 is attributed to P and 7:1–5 to J, the two texts, while containing some repetition, are actually consecutive. The P material is prior to the building of the ark and the J material is a speech of God after its completion but prior to the beginning of the flood. The repetition heightens the dramatic anticipation of the deluge to follow and is not indicative of two separate documents having been combined.
 - iv. Similarly, Genesis 7:21 and 22 are viewed as redundant, with v. 21 being assigned to P and v. 22 to J. However, the two verses are simply chiasmic: (A) They perished (B) Every living thing that moves on the earth... (B') Everything that has the breath of the living spirit... (A') They died. This suggests a single, unified narration (so F. Anderson, *The Sentence in Biblical Hebrew*, 40).
 - v. Gordon J. Wenham has also observed a high level of literary balance and symmetry of structure that would be lost if the flood account was not originally a unified whole (so “The Coherence of the Flood Narrative,” *Vetus Testamentum* 28 [1978] 338).

Fig. 2.9. The Unified Structure of the Flood Narrative in Genesis 6:10–9:19
 Gordon J. Wenham, "The Coherence of the Flood Narrative," *Vetus Testamentum* 28 (1978): 338.

A	Noah (6:10a)
B	Shem, Ham, and Japheth (10b)
C	Ark to be built (14–16)
D	Flood announced (17)
E	Covenant with Noah (18–20)
F	Food in the ark (21)
G	Command to enter the ark (7:1–3)
H	7 days waiting for flood (4–5)
I	7 days waiting for flood (7–10)
J	Entry to ark (11–15)
K	Yahweh shuts Noah in (16)
L	40 days of flood (17a)
M	Waters increase (17b–18)
N	Mountains covered (19–20)
O	150 days waters prevail ([21]–24)
P	GOD REMEMBERS NOAH (8:1–2)
O'	150 days waters abate (3)
N'	Mountain tops visible (4–5)
M'	Waters abate (5)
L'	40 days (end of) (6a)
K'	Noah opens window of ark (6b)
J'	Raven and dove leave ark (7–9)
I'	7 days waiting for waters to subside (10–11)
H'	7 days waiting for waters to subside (12–13)
G'	Command to leave the ark (15–17[22])
F'	Food outside the ark (9:1–4...)
E'	Covenant with all flesh (8–10)
D'	No flood in the future (11–17)
C'	Ark (18a)
B'	Shem, Ham, and Japheth (18b)
A'	Noah (19)

h. Anachronisms

- i. General statement: No one questions that the grammar and some geographical references have been updated to clarify for later generations the meaning of the text; this is a far cry for complete editorial overhaul.
- ii. The Philistines: While it is true that the Philistine inscriptions begin only in the 12th century, much of their early trade was in perishable goods. It is well known that at this time trade was wide spread in the Mediterranean, and Aegean goods have been found at Ras Shamra. Furthermore, the fact that Ramses II is the first to mention the Philistines on his stele in 1195 does not mean that they were not in the area prior to that. This is an argument from silence.
- iii. Camels: The first archaeological mention of the domesticated camel is on a cuneiform tablet dated in the 18th century B.C. (See J. Zarins, *ABD* 1:824–26). The Scriptures agree with archaeology that, although camels were domesticated early, their use was not widespread.
- iv. Key expressions:
 - (1) “Before any king ruled in Israel”: Mosaic authorship does not demand that every word was written by Moses. A later scribe may have inserted this as an observation, but he did so without doing any violence to the truthfulness of the text, and with the blessing of the Holy Spirit. This stated, Moses elsewhere

predicated the day when a king would be ruling in Israel (Deut. 17:14–20), and a royal Messianic hope is found from the earliest parts of Genesis (3:15; 17:6, 16; 22:17b–18; 35:11; 49:8–10; Num. 24:17–19).

- (2) “The Canaanites were then in the land”: There never was a time when the Canaanites were not in the Land, even after David’s consolidation of the empire. This is imply a statement explaining why Abraham was prevented from taking the land.
- i. Textual references to Moses
 - i. The use of the third person is common in early histories: Xenophon, *Anabasis*; J. Ceasar, *The Galic Wars*. The fact that specific portions are attributed to Moses is more an argument for Mosaic authorship (he was involved in some writing task) than against it.
 - ii. The comment regarding Moses’ death and succession at the end of the Pentateuch (Deut. 34:1–12) was likely an obituary or epilogue added by the editor of Deuteronomy, who also introduced the book (Deut. 1:1–4), clarified geo-historical data (2:10–11, 20–23; 3:9, 11, 13b–14; 10:6–7), and seamed together Moses’ messages (e.g., 1:5; 4:41–43, 44–5:1a; 29:1). The presence of such an editor in Deuteronomy is suggested within the final form of the text itself, for to Moses, the Promised Land to the west was considered “beyond the Jordan” (Deut. 3:20, 25; 11:30; cf. Num. 32:19), where, for the editor, Moses and Israel’s placement in Moab was “beyond the Jordan” (Deut. 1:1, 5; 3:8, 35; 4:41, 46–47, 49). The substantial Mosaic authorship of the Pentateuch is not called into question with the above view. When crossing the Jordan, Israel most likely had Genesis–Numbers in substantially the form we have them, along with a folder of the three Deuteronomic sermons, the warning song, and Moses’ death-bed blessing.
4. Conclusion:
 - a. Traditionally, literary analysis has been defined as source analysis, which is by nature “excavative” or “deconstructive.” The attempt was to look behind the final form of the text as it comes to us in order to establish its compositional history. However, reconstructing the Pentateuch’s compositional history is a highly speculative task, and as R. W. Moberly has stated, “Critical conjectures that depend on reading between the lines are always more persuasive if combined with a cogent reading of the lines themselves” (*The Old Testament of the Old Testament: Patriarchal Narratives and Mosaic Yahwism*, OBT [Minneapolis, MN: Fortress, 1992], 85 n.4). Traditional deconstructionist source critics do an injustice to the biblical text by failing to appreciate what the text itself communicates in the form we have it.
 - b. The effort to establish sources is not by nature wrong, and the authors of Joshua, Judges, Samuel, Kings, Luke, and likely every other historical book in the Bible used sources where the author himself was not a witness to the

events. This means that the presence of sources can still be compatible with the idea of Mosaic authorship (see esp. Garrett, *Rethinking Genesis*).

- c. However, any approach to sources must treat both alleged sources and the final form with integrity and authority and view the latter alone as the Scripture of the Church. Canonical analysis serves as a helpful corrective to approaches that see only individual trees or parts of trees without accounting for the forest.
- d. Since the 1970s, a new, more helpful and balanced form of “literary criticism” has arisen that is focused on the final form. Robert Alter defines it this way (*The Art of Biblical Narrative*, 12): “The manifold varieties of minutely discriminating attention to the artful use of language, to the shifting play of ideas, conventions, tone, sound, imagery, syntax, narrative viewpoint, compositional units, and much else; the kind of disciplined attention in other words, which through a whole spectrum of critical approaches has illuminated [literary works of all kinds].” This kind of analysis is needed more in contemporary OT studies.

D. An Initial Response to the Challenges Related to Questions of Historicity

1. An example of the challenge—T. Thompson’s “Historical and Christian Faith,” in *Israel’s Past in Present Research*, 480–84:
 - a. The biblical text alone is what is authoritative and that which gives rise to our faith; faith grows out of the Bible’s message and is not related to the historicity of the events addressed (481–82).
 - b. The patriarchal traditions are *story* not history, for archaeological evidence has not validated the stories nor shown them to be likely (481).
 - c. All of “salvation history” is a literary construct and did not actually happen (482).
 - d. Faith, therefore, grows out of a created past that includes created promises to instill present hope (482–83).
 - e. Faith’s “demands” cannot create the historical.
2. A Conservative Response—Relating Faith, Story, and History:
 - a. **Priority lies with texts.** Social sciences (archaeology, anthropology, sociology, etc.) deal only with general features of societies and cultures; texts alone clarify specific events and individuals.
 - b. **Historicity and authority go hand-in-hand.** Because the Bible is God’s revelation (2 Tim. 3:16), its historicity and authority are intimately united.
 - c. **The mention of the divine or supernatural events does not mean unhistorical.** Even if one unhelpfully confines oneself to an a-theistic approach to history, the presence of “divine intrusion” or the supernatural must be understood as cultural or religious encoding and should not be seen as evidence that a narrative in whole deals with imaginary or fabricated events. For example, Edwin Yamauchi has observed (“The Current State of Old Testament Historiography,” in *Faith, Tradition, & History* [Eisenbruans, 1994], 27–28):
 - i. Herodotus’ belief in the Delphic Oracles does not disqualify him as an accurate source for Greek history.

- ii. Darius' involving of Ahura Mazada (noted 69x in the text) does not stop Persian historians from viewing Darius' Behistun Inscription as the most informative Old Persian text.
- iii. No one doubts Joan of Arc's arousal of her countrymen to push English forces out of France, even though this action was apparently grounded in an unverifiable divine call to action.
- d. **Verifiability is not essential.** Confirming biblical claims with extra-biblical data must not be viewed as essential, for there are too many gaps in our knowledge of the past; "archaeological support" should not be expected for the patriarchs, but we do know that the details of the patriarchal stories fit nicely into the time period of which they propose to be a part.
- e. **Innocent until proven guilty.** There is no evidence that Israel falsified or invented statements of fact, and this is highly unlikely due to the nature of the message and the judgment the text itself places on false teachers (e.g., Deut. 13:1–5); with this, no other field of historical research practices a "guilty until proven innocent" approach, so why should this be done in biblical studies?
 - i. The Egyptian Fourteenth Dynasty consisted of about 76 kings, most of whom are listed in the Turin Papyrus of Kings, which dates to the Nineteenth Dynasty, 500 years after the period of the 14th Dynasty kings were to have reigned. Although hardly a single definite contemporary monument of any Delta kings has been recovered, Egyptologists do not deny the existence of these kings. How much more should this be the case with the people and situations of Scripture that were of no interest to non-Hebrews who might otherwise have provided confirmatory source material. (Kenneth A. Kitchen, *Ancient Orient and Old Testament* [InterVarsity, 1975], 30)
 - ii. Most of the works of Livy, the first books of the history of the Franks by Gregory of Tours, contain events known only from these sources, yet historians do not deny that these events actually happened (G. J. Reiner, *History: Its Purpose and Method*, 90–91, as cited by Craig L. Blomberg, *The Historical Reliability of the Gospels*, 241).
 - iii. When writing about the historical veracity of the Israelite conquest of Canaan, B. S. J. Isserlin compares three conquests in later history that are well documented: (1) the Arab invasion of Palestine in the 7th century A.D.; (2) the invasion of Britain by the Anglo-Saxons in the 5th century A.D.; and (3) the invasion of England by the Normans in 1066 A.D. Like the Israelite conquest, each of these later "histories" speak of numerous destructions, but the archaeological evidence is minimal or non-existent. No scholars deny that these historical events occurred, so one may legitimately ask why an event like the Israelite conquest of Canaan is questioned, though the archaeological witness is difficult to line up. (Isserlin, B. S. J. "The Israelite Conquest of Canaan," 85–94, as cited by Yamauchi, "The Current State of Old Testament Historiography," 36)

- iv. It was not until 1932 that the Babylonian exile of Jehoiachin was recognized on extra-biblical tablets. Similarly, epigraphical attestation of Pontius Pilate was only found in 1961 and of Felix the procurator in 1966. (Yamauchi, “The Current State of Old Testament Historiography,” 26–27)
- v. Only in 2002 was there any archaeological or epigraphic evidence uncovered that directly mentioned Jesus, his brother James, and their father Joseph (see the James Ossuary).
- f. **God’s revelation in history is the source, not the product, of “biblical faith.”** Biblical faith is grounded in God’s revelation in history, and the significance of the biblical testimony stands or falls on whether or not the “central events” actually happened (e.g. whether Jesus was raised or not, see 1 Cor. 15:14); furthermore, if the “central events” are viewed as historical, the other “non-central” events are given a certain amount of veracity.
- g. **Taking the Bible on its own terms requires a Christian theistic rather than an a non-Christian atheistic approach to interpretation.** Because all who approach the Bible come with certain assumptions about the nature of reality (i.e., faith claims), one must choose between theistic and atheistic approaches to Scripture. Only the former allows the Bible to be taken on its own terms.

E. Summary Support for the Traditional View of Substantial Mosaic Authorship of the Pentateuch

- 1. The Egyptian details in the Joseph and Egyptian plague stories strongly suggests the author of the Pentateuch was someone familiar with Egyptian culture.
- 2. The clear awareness of political treaty patterns of the 2nd millennium suggests a 2nd millennial origin from someone acquainted with international affairs.

Fig. 2.10. Ancient Near Eastern Treaty Forms and Biblical Covenants

(II) Early & Mid-2nd Millennium		(III) Mid to Late 2nd Millennium			(IV) 1st Millennium	
Mari & Leilan	Patriarchs	Mid-Hittite	Later Hittite	Exod, Deut, Josh	Sfire	Assyria
Witnesses Oath Stipulations	Witnesses Oath Stipulations	Title Witnesses Stipulations	Title Prologue Stipulations	Title Prologue Stipulations	Title Witnesses Curses Stipulations	Title Witnesses Stipulations
Curses	Curses	Oath Curses	Deposit Witnesses Curses Blessings	Deposit Witnesses Blessings Curses		Curses

Taken from K. A. Kitchen, “The Fall and Rise of Covenant, Law and Treaty,” *Tyndale Bulletin* 40 (1989): 118–35, esp. 128.

- 3. In Genesis, a sense of homelessness and alienation combined with an optimistic anticipation of entering the Promised Land suggests the wilderness wanderings as the most likely context for the book’s origin.
- 4. Moses, the key human figure in the Pentateuch, is a perfect candidate for having penned most of the Pentateuch.

- a. He was raised as an Egyptian prince, educated in the house of Pharaoh gaining “all the wisdom of the Egyptians” (Acts 7:22).
 - b. He was the main messenger of deliverance from Egypt and the mediator between Yahweh and Israel through the covenant at Mount Sinai through the wilderness wanderings.
5. Numerous passages state that Moses had a key hand in writing at least some of the Pentateuch (e.g., Exod 24:4; Deut 31:24; John 5:46–47) (see above).
 6. Many linguistic features point to a 2nd millennial origin of the Pentateuch (see Appendix A.2.2, “Linguistic Analysis and the Dating of the Pentateuch”).
 7. Conclusion: the traditional view is a sound view.
 - a. So long as one approaches the text theistically, one can justifiably view the Pentateuch as containing a historically accurate account of past events upon which faith can be based.
 - b. As long as one allows for earlier sources (though not in the form of JEDP), later glosses, and later (though minimal) editorial elaboration and stitching, it is possible to affirm the substantial Mosaic authorship of the Pentateuch.